



Single-use Cell-Culture Wells for high resolution Live-Cell Imaging

UNI EN ISO 11137-1/2/3: SAL 10
STERILE R

Borosilicate-glass-bottom
wall: PS/white



Caution: Broken glass can be hazardous

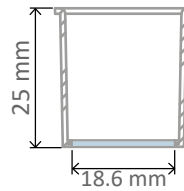
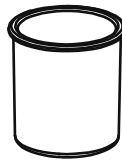

Growth area 2.7 cm²

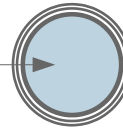

Copyright © 2020 by Hektros srl.

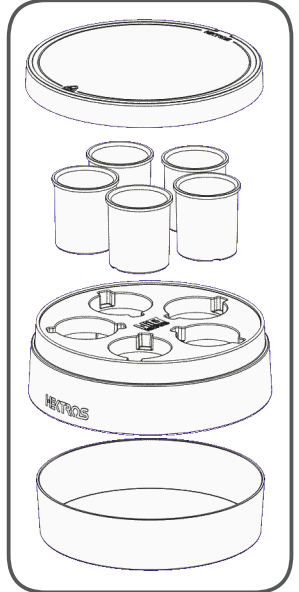

H5D-A01: Borosilicate-glass-bottom 0.16 mm; wall: polystyrene; 1 pkg. / 5 pcs.
With carrier element and HiCult as protective dish

5x Hi5i CC-Well-Inserts

1x Hi5i Carrier element

1x HiCult Dish

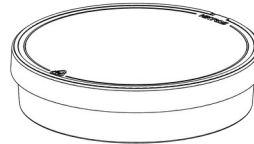
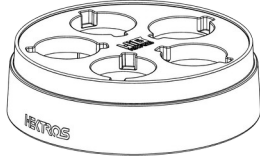

Please find further information and application videos on www.hektros.com!

Quickguide - Hi5i Cell-Culture-Wells

1. Seed cells under **sterile conditions** with Hi5i-CC-wells seated in the Carrier element

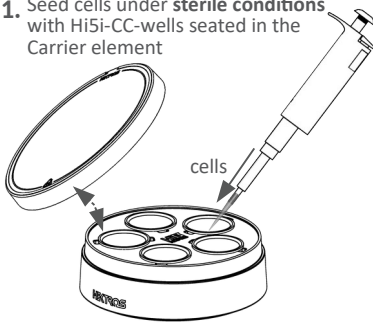

2. Transport the Hi5i Carrier element by pressing the bottom side. Use thumb and index or middle finger. The protective dish should be lifted together with the carrier.

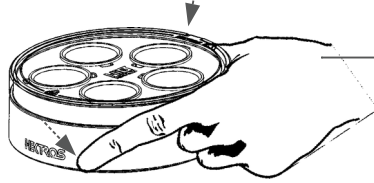

Note: Keep the Lid closed for sterile conditions.

3. Cultivate the cells in a CO₂-Incubator if needed.

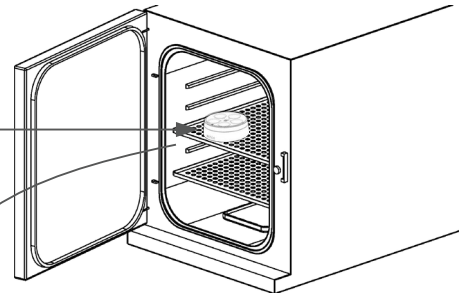

A: use with the Hi5 LCI-Incubator

B: stand alone use with a microscope

A1 Use tweezers to transfer the Hi5i-Wells into the Hi5 seats under **sterile conditions**

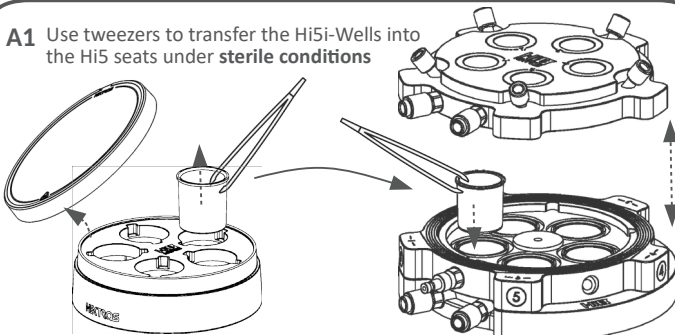

Note: Close the Hi5 LCI-Incubator before moving to the microscope! Please refer to the Hi5 LCI-Incubator manual. Hi5 Incubator not included.

B1 Remove the **protective dish** for better results when examining with a microscope. To remove the protective dish grab the upper part of the carrier-element and press very gently. The protective dish should remain on the table when lifting the carrier.

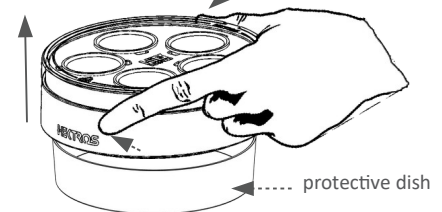

Note: Keep the Lid closed for sterile conditions.

A2 Place the **Hi5 LCI-Incubator** on the stage of the Inverse-Microscope.

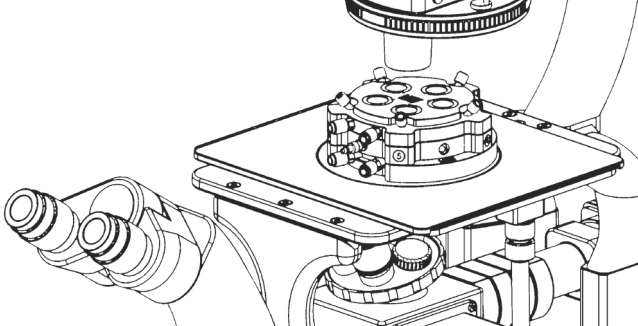

Note: Please refer to the Hi5 LCI-Incubator Manual for further steps.

B2 Place the **Hi5i Carrier** on the stage of the Inverse-Microscope.

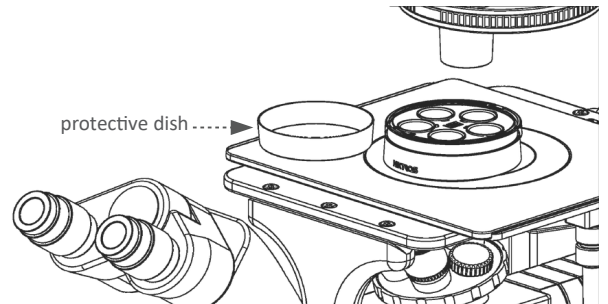

Note: Keep the Lid closed for sterile conditions.